

BLACKHAWK®



 Pulling towers

 Tours de traction

 Zugtürme

 СИЛОВЫЕ БАШНИ



COMPOSITION • COMPOSITION • ZUSAMMENSTELLUNGEN • СОСТАВ

	PTK10A	
1	PTK100	1
2	PTK101	2
3	PMP8130	1
4	AEK 99	1
5	AEK 304	1

OPTION • OPTION • OPTIONAL • ОПЦИЯ
 PTK11

Push accessory / Accessoire de poussée / Druckzubehör /
 ПРИСПОСОБЛЕНИЯ ДЛЯ ВЫТАЛКИВАНИЯ

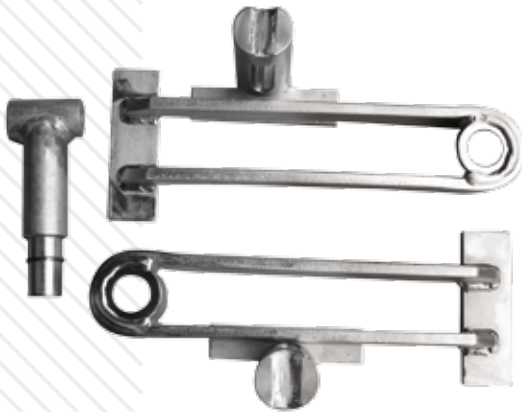

PTK10A

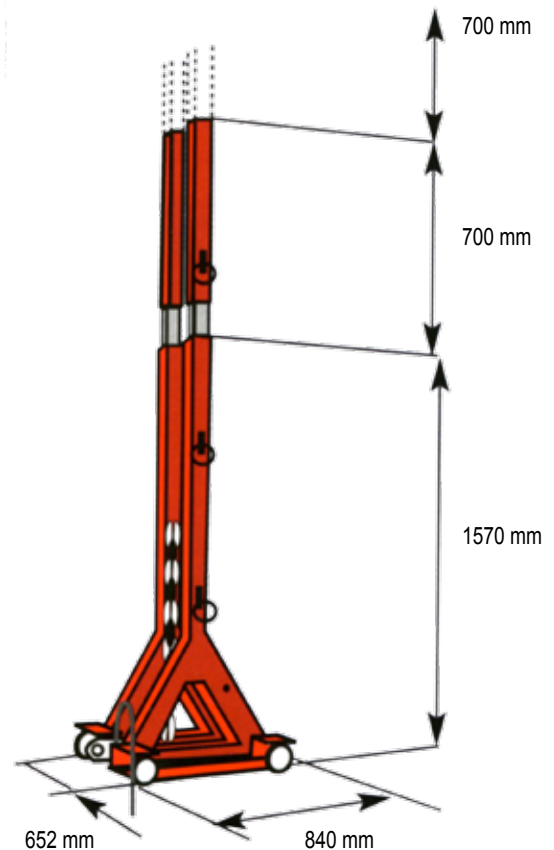

COMPOSITION • COMPOSITION • ZUSAMMENSTELLUNGEN • СОСТАВ

		HD85B	HD86B
1	HD850A	1	1
2	PMP8110	1	1
3	АЕК99	1	1
4	АЕК304	1	1
5	АЕК307	2	1
6	HD851A		2
7	АЕК328*		2

*not shown / non représenté / nicht abgebildet / НЕ ПРЕДСТАВЛЕН

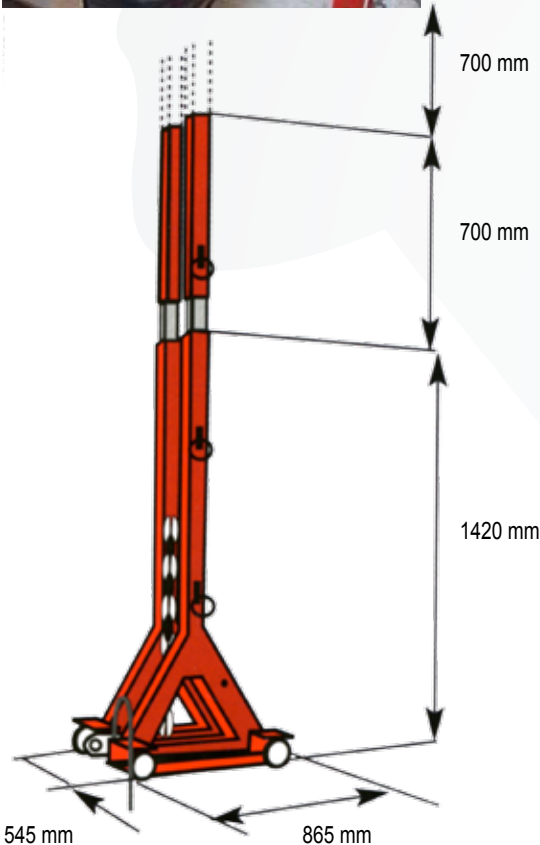

OPTION • OPTION •
OPTIONAL • ОПЦИЯ
HD851A

700 mm
Extension
Rallonge
Verlängerung
УДЛИНИТЕЛЬ

6



COMPOSITION • COMPOSITION • ZUSAMMENSTELLUNGEN • СОСТАВ
HD71B

	HD71B	HD72B
1	HD700A	1
2	HD703A	1
3	HD704A	1
4	HD99	1
5	HD332	2
6	HD8307	2
7	Z219	3
8	PMP8130	1
9	LX22X*	1

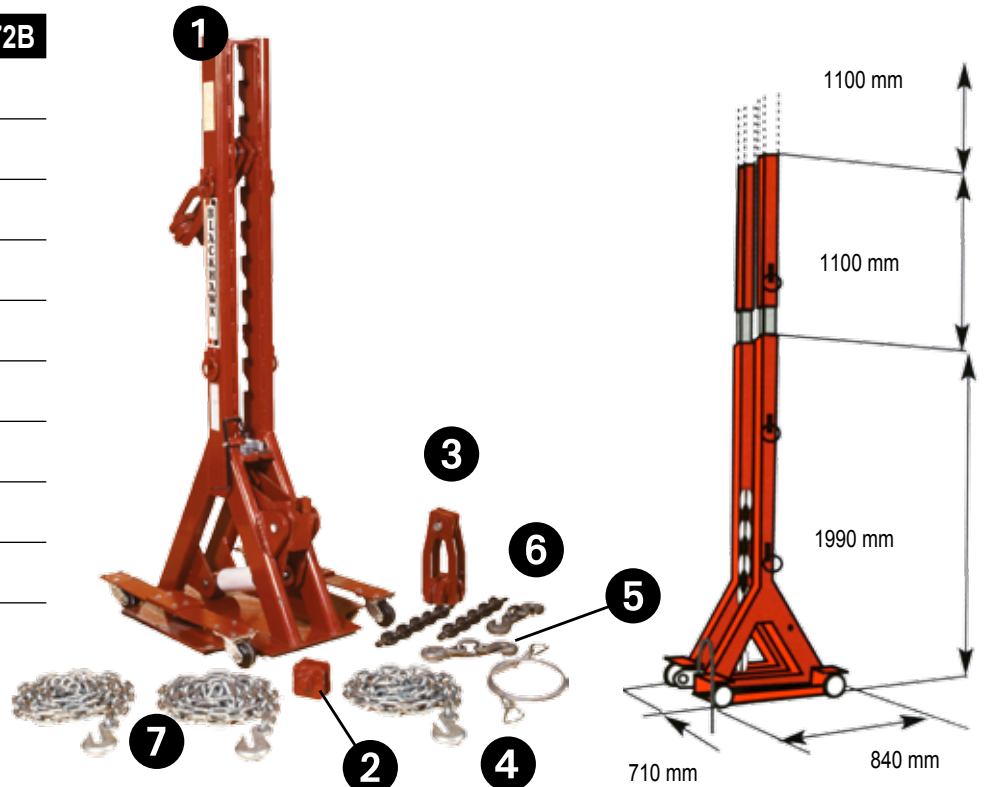

* not shown / non représenté / nicht abgebildet / НЕ ПРЕДСТАВЛЕН

OPTION • OPTION • OPTIONAL • ОПЦИЯ

HD701A

1100 mm

Extension
Rallonge
Verlängerung
удлинитель



HDY7005



Low height pull accessory
Outil de traction basse
Umlenkrolle für niedrige Züge
УСТРОЙСТВО ДЛЯ НИЖНЕГО
РАСТЯЖЕНИЯ

PULL • TRACTIONS • ZÜGE • РАСТЯЖЕНИЯ

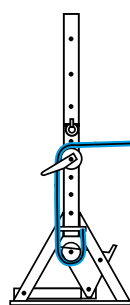

6,80 T
Single pull

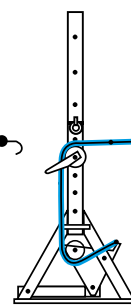

13,60 T
Single pull

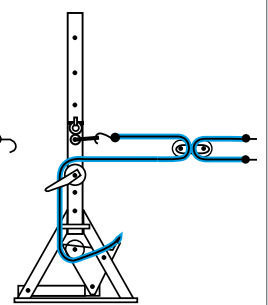

13,60 T
Double pull

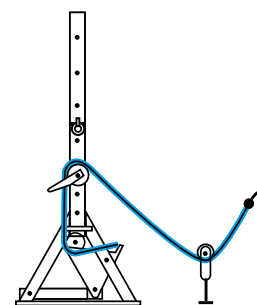

13,60 T
Downward pull

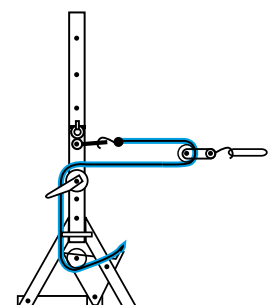

27,20 T
Pulley block developing

**PULLEY BLOCK DEVELOPING / PAR MOUFLAGE
/ MIT UMLENKROLLE / С ТАЛЕВОЙ СИСТЕМОЙ**

HD85B + 97605E



HD71B + HD704A



**HIGH PULL LEVEL / TRACTION HAUTE / ZUGARBEIT
AUF HOHE ZÜGE / ВЕРХНЕЕ РАСТЯЖЕНИЕ**

HD85B + HD851A



HD71B + HD701A



ANCHOR POTS • Puits d'ancrage • ANKERTÖPFE • АНКЕРНЫЕ СТАКАНЫ

Easy and quick installation

Installation rapide et facile

Schnelle und einfache installation

БЫСТРАЯ И ПРОСТАЯ УСТАНОВКА

For drilling and installation plans please contact your Blackhawk distributor

Pour tous travaux de forage et d'installation contacter Blackhawk

Für Planung und Borarbeiten wenden Sie sich bitte an ein Blackhawk Mitarbeiter

**ПО ВСЕМ БУРОВЫМ И УСТАНОВОЧНЫМ РАБОТАМ
ОБРАЩАЙТЕСЬ К ФИРМЕ BLACKHAWK**



TD130 E



Ø 89 mm

TD135 E



Ø 89 mm

TD335 E

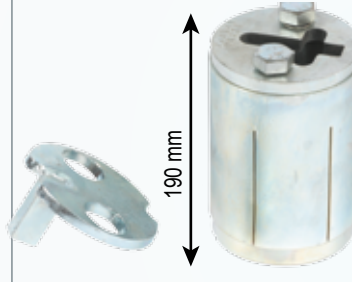

Ø 127 mm

TD330 E



Ø 127 mm

TD130 E - TD135 E

Anchor pots with chain slot for use with Power Post® pulling tower.

Puits avec encoche, à utiliser avec tour de traction Power Post®.

Ankertöpfe mit Kettenaufnahme passend für Power Post® Zugturm.

ДЛЯ СИЛОВЫХ БАШЕН POWER POST® ИСПОЛЬЗОВАТЬ СТАКАНЫ С ВЫЕМКОЙ

TD330 E - TD335 E

Anchor pots with chain slots with larger diameter for use with King Power Post® and Maxi Tower pulling towers.

Puits d'ancrage avec encoches pour chaînes plus larges, pour utilisation avec les tours King Power Post® et Maxi Tower.

Ankertöpfe mit Kettenaufnahme passend für King Power Post® und Maxi Tower.

**ДЛЯ СИЛОВЫХ БАШЕН KING POWER POST® И MAXI TOWER
ИСПОЛЬЗОВАТЬ АНКЕРНЫЕ СТАКАНЫ С ВЫЕМКАМИ ДЛЯ БОЛЕЕ
ШИРОКИХ ЦЕПЕЙ**

Optional accessories / Accessoires en option / Zubehör in Option / ОПЦИОННЫЕ ПРИСПОСОБЛЕНИЯ

Other accessories see "accessories catalogue"
Accessoires supplémentaires voir "catalogue accessoires"
Mehrere Zubehör sehe "Zubehör Katalogue"
Дополнительные приспособления смотреть в
«каталоге приспособлений»

HD8305

14,5 kg

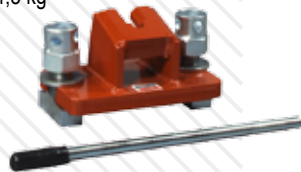

20 T Chain anchor for I beam frame
Ancrage de chaîne 20 T pour IPN 200
20 t Kettenverankerung für IPN 200
Анкерное крепление цепи 20 T для IPN 200

K179038 + 2 x K238320

3,1 kg



Ram foot 10 T
Crapaudine 10 T
Bodenlager mit Keile 10 t
Подпятник 10 T

HD 8301 + 2 x K238320

7,8 kg



20 T Chain anchor for Korek® frame
Ancrage de chaîne 20 T pour châssis Korek®
20 t Kettenverankerung für Korek® Rahmen
Анкерное крепление цепи 20 T для стальной рамы Korek

HD8306 + 2 x K238320

7,8 kg



10 T Chain anchor for I beam 200
Ancrage chaîne 10 T pour IPN 200
10 t Kettenverankerung für IPN 200
Анкерное крепление цепи 10 T для IPN 200

HD8303

4 kg



Chain tensioner 20 T
Tendeur 20 T
Kettenspanner 20 t
Натяжное устройство цепи 20 T

HD8302

4,78 kg



10T hook + 20T chain,
Crochet 10T + 20T chaîne
10 t Haken + 20 t Kette
Крюк 10 T + цепь 20 T
Intermediate tensioner 10 T
Tendeur de chaîne 10 T
Spanner 10 t
Натяжное устройство цепи 10 T

АЕК329 / АЕК419

2 kg

2,3 kg



Measuring gauge 900/2600 mm
950/3250 mm
Pige télescopique 900/2600 mm
950/3250 mm
Telescop Messlehre 900/2600 mm
950/3250mm
Телескопическая линейка 900/2600 MM
950/3250MM

АЕК2001

0,450 kg



Pull strap assy 8 T
Sangle de traction 8 T
Zuggurt 8 t
ТЯГОВЫЕ ЛЯМКИ 8 T

PT318A

2,4 kg



Adapter hook 10-20 T
Double crochet 10-20 T
Doppelhaken 10-20 t
Двойной крюк 10-20 T

97272

12 kg



Frame hook (alu)
Crampon (alu)
Spezialzughaken (alu)
Скоба (алюминиевая)

PT114A

8 kg



Grab hook + chain- POWER CAGE
Crochet d'ancrage + chaîne - POWER CAGE
Greifzughaken + Kette- POWER CAGE
Анкерный крюк + цепь

HDY25

50 kg



23 T Hydraulic stand
530 -1166 mm
Chandelle + vérin 23 T
530 - 1166 mm
hydraulische Unterstellbock 23 t
530 - 1166 mm
Стойка + домкрат 23 T
530 -1166 мм

АЕК281

16,5 kg

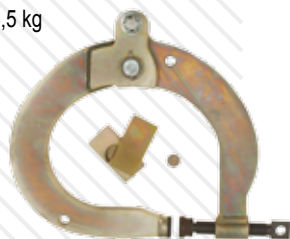

Wide opening clamp
Pince à grand dégalement
Zugklammer mit grosser Öffnung
Захват с большим выносом

PT115

4,78 kg



Super grab hook + chain - alu frame
- KING POST
Crochet d'ancrage + chaîne - châssis alu - KING POST
Greifzughaken + kette - alu rahmen - KING POST
Анкерный крюк + цепь-алюминиевая рама - KING POST

HDY2003

23 kg



Vertical pull pulley without chain
Poulie pour traction verticale sans chaîne
Kettenverankerung mit Rolle ohne Kette
Блок для вертикальной тяги без цепи

LAYOUT EXAMPLES FOR ANCHOR POTS AND FRAME RAILS /
 EXEMPLES D'IMPLANTATION DES Puits D'ANCRAGE ET CHASSIS AU SOL /
 VORSCHLAG FÜR ANKERTOPF-UND SCHIENENANORDNUNG /
 ПРИМЕРЫ УСТАНОВКИ АНКЕРНЫХ СТАКАНОВ И СТАПЕЛЬНОЙ РАМЫ НА ПЛОЩАДКЕ

16 M X 8 M
 TD 330E / TD130E

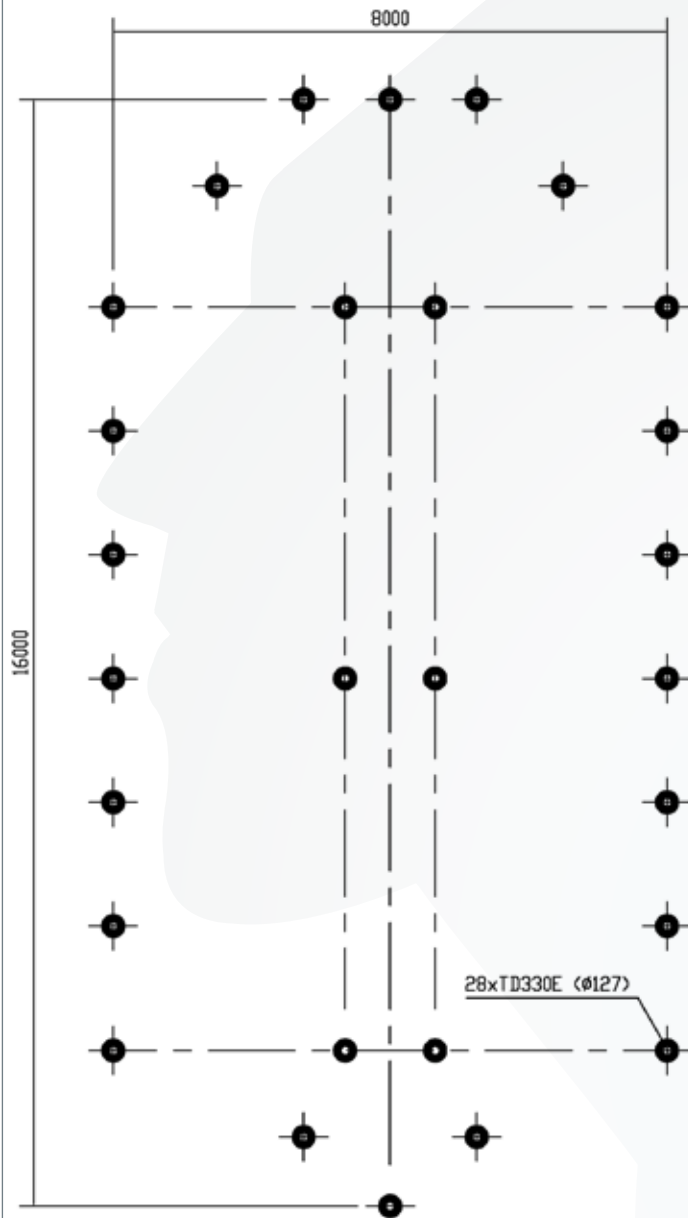

KOREK® KOR85B + KOR71B - 16 M X 8 M
 TD 330E / TD130E

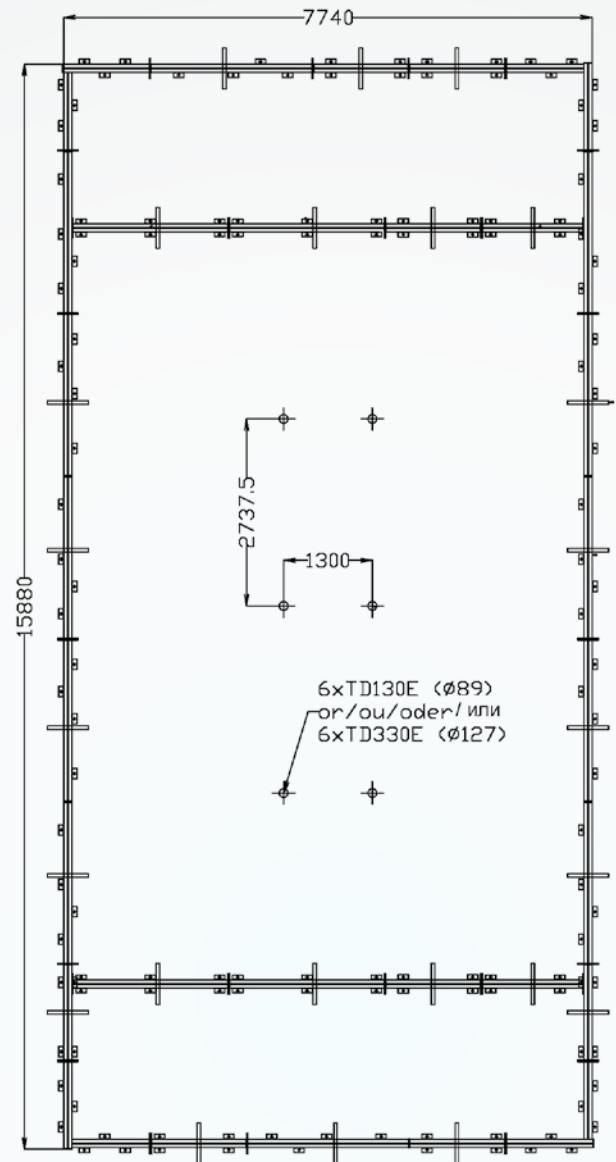

Personalized Layouts for frame rails available on request
Plans de châssis personnalisés disponibles à la demande
 Auf Anfrage individuell gestaltete Schienen Anordnungen erhältlich
 СТАПЕЛЬНЫЕ РАМЫ В НАЛИЧИИ ПО ЗАКАЗУ

BLACKHAWK®



BLACKHAWK SA

France - Benelux : BP 5 - 67026 Strasbourg Cedex - FRANCE

Tél. 03 88 65 76 30 - Fax 03 88 65 76 31 - E-Mail : info@blackhawk.fr - www.blackhawk.fr

International Sales : BP 5 - 67026 Strasbourg Cedex - FRANCE - www.blackhawk.fr

Tel. +33 3 88 65 76 29 - Fax +33 3 88 65 76 51 - E-Mail : export@blackhawk.fr

Deutschland - Schweiz - Österreich : BP 5 - 67026 Strasbourg Cedex - FRANCE

Tel. +33 3 88 65 76 52 - Fax +33 3 88 65 76 31 - E-Mail : info@blackhawk.de - www.blackhawk.de

SNAP-ON EQUIPMENT SRL - BLACKHAWK ITALIA :

Via Provinciale Carpi 33 - I-42015 Correggio - RE - ITALY

Tel. 0522 733620 - Fax 0522 733621 - E-Mail : blackhawk@snapon.com - www.blackhawk.it

SNAP-ON EQUIPMENT - BLACKHAWK UK :

48 Suttons Park Avenue - Reading RG6 1AZ - UK

Tel. 01303 270273 - Fax 01303 270274 - Email: sales@blackhawk.co.uk - www.blackhawk.co.uk



0101-0101-0101-0101-0101-0101-0101-0101-0101-0101

Blackhawk reserves the right to make changes in the catalogue at any time • Blackhawk se réserve le droit de modifier à tout moment les caractéristiques indiquées dans ce catalogue •
Blackhawk оставляет за собой право в любое время изменять характеристики, приведенные в настоящем каталоге.
Technische Änderungen ohne Vorankündigung vorbehalten.

